

RT19264D-1

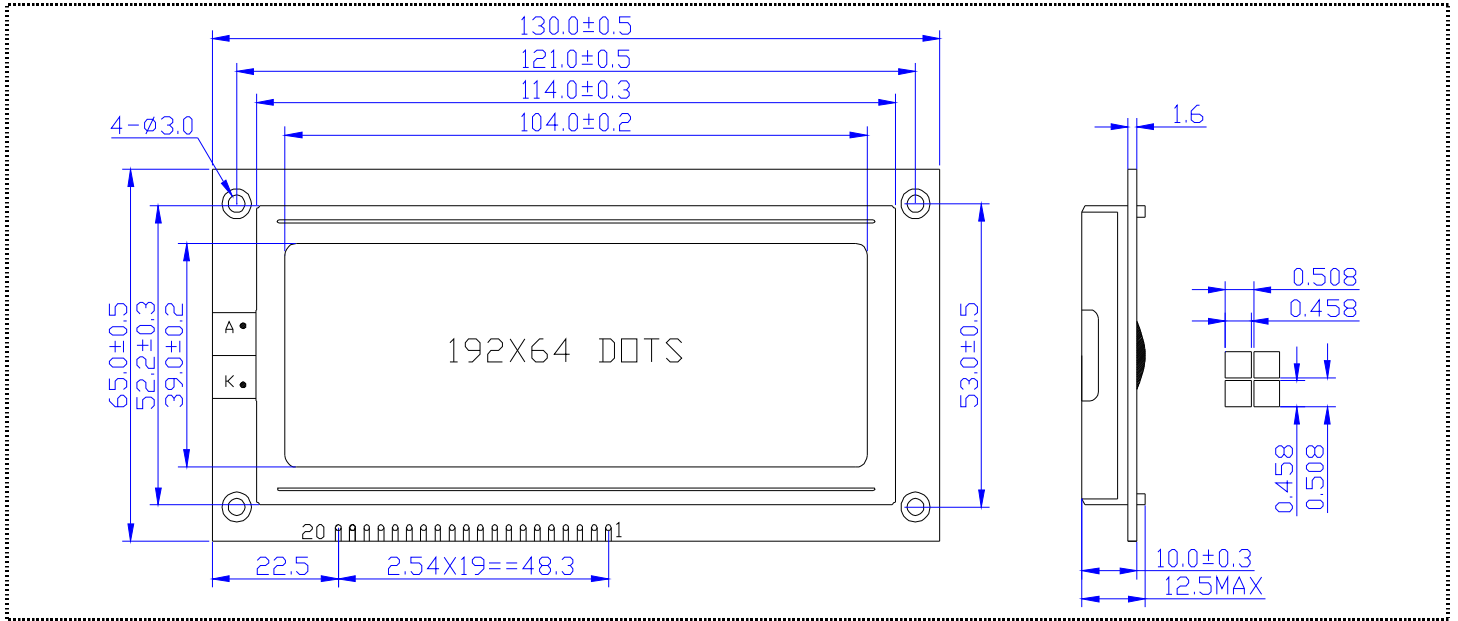

MECHANICAL DATA

Item	Nominal Dimensions	Unit
Module Size(W×H×T)	130.0×65.0×12.5	mm
Viewing Area(W×H)	104.0×39.0	mm
Dot Pitch(W×H)	0.508×0.508	mm
Dot Size(W×H)	0.458×0.458	mm

PIN CONNECTIONS

PIN	Symbol	Level	Function
1	VSS	—	GND(0V)
2	VDD	—	Supply Voltage for Logic(+5V)
3	V0	—	Power supply for LCD
4	/RST	L	Reset Signal (Active LOW)
5	RS/CS	H/L	H: Data; L: Instruction Code/Chip select
6	RW/SID	H/L	H: Read; L: Write(Parallel)/Data(Serial)
7	E1/SCLK1	H/L	Upper Screen: Enable Signal(Parallel) / Serial Clock
8	E2/SCLK2	H/L	Under Screen: Enable Signal(Parallel) / Serial Clock
9	PSB	H/L	H:Parallel Mode; L:Serial Mode
10	DB0	H/L	Data Bus Line
11	DB1	H/L	
12	DB2	H/L	
13	DB3	H/L	
14	DB4	H/L	
15	DB5	H/L	
16	DB6	H/L	
17	DB7	H/L	
18	LEDA	—	Backlight Power (+5V)
19	LEDK	—	Backlight Power (0V)
20	VOUT	—	Voltage Doubler Output

ABSOLUTE MAXIMUM RATINGS

Item	Symbol	Min	Type	Max	Unit
Operating Voltage	VDD	4.5	5.0	5.5	V
Operating Current	IDD	4.8	5.2	5.5	mA
LED Voltage	V _{LED}	4.5	5.0	5.5	V
LED Current	I _{LED}	118	125	130	mA
Operating Temp	Topr	-10	—	+70	°C
Storage Temp	Tsto	-20	—	+80	°C

ELECTRICAL CHARACTERISTICS

Item	Symbol	Min	Type	Max	Unit
Input High Voltage	V _{IH}	0.7VDD	—	VDD	V
Input Low Voltage	V _{IL}	0	—	0.6	V
Output High Voltage	V _{OH}	0.8VDD	—	VDD	V
Output Low Voltage	V _{OL}	0	—	0.4	V

BLOCK DIAGRAM

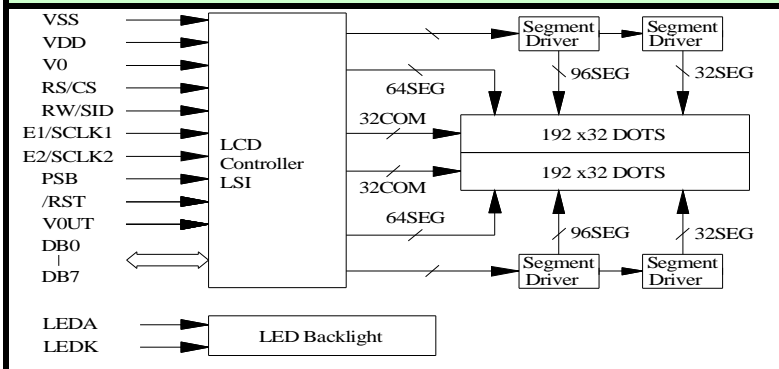

POWER SUPPLY

