

# HF1601E

SHANGHAI HENGFANG ELECTRONIC CO.,LTD  
 Address: 上海市北京东路668号 赛格电子 2A13 B318  
 Tel:021-53085818 53081376 51571718  
 FAX:021-53085818 Postcode:200010  
 E-Mail:wanghx70@163.com Http://www.hengfang.com.cn

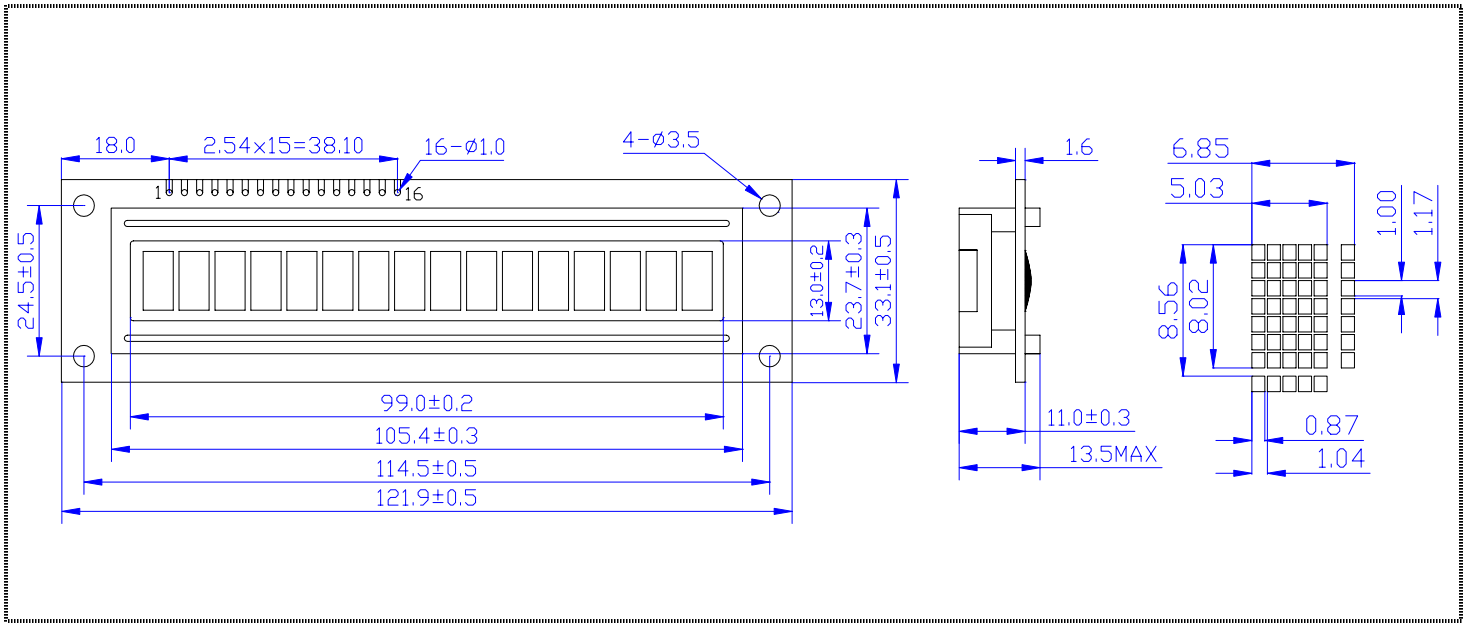

MECHANICAL DATA		
Item	Nominal Dimensions	Unit
Module Size(W×H×T)	122.0 × 33.0 × 13.5	mm
Viewing Area(W×H)	99.0 × 13.0	mm
Character Size(W×H)	5.03 × 8.02	mm
Dot Size(W×H)	0.87 × 1.04	mm

PIN CONNECTIONS			
PIN	Symbol	Level	Function
1	VSS	—	GND(0V)
2	VDD	—	Supply Voltage for Logic(+5V)
3	V0	—	Power supply for LCD
4	RS	H/L	H: Data ; L: Instruction Code
5	R/W	H/L	H: Read ; L: Write
6	E	H/L	Enable Signal
7	DB0	H/L	Data Bus Line
8	DB1	H/L	
9	DB2	H/L	
10	DB3	H/L	
11	DB4	H/L	
12	DB5	H/L	
13	DB6	H/L	
14	DB7	H/L	
15	BL1	—	Backlight Power(+5V)
16	BL2	—	Backlight Power(0V)

ABSOLUTE MAXIMUM RATINGS					
Item	Symbol	Min	Type	Max	Unit
Operating Voltage	VDD	4.5	5.0	5.5	V
Operating Current	IDD	1.2	1.5	2.0	mA
LED Voltage	V <sub>LED</sub>	1.5	5.0	5.0	V
LED Current	I <sub>LED</sub>	90	164	230	mA
Operating Temp.	Topr	0	—	+50	
Storage Temp.	Tsto	-10	—	+60	

ELECTRICAL CHARACTERISTICS					
Item	Symbol	Min	Type	Max	Unit
Input High Voltage	V <sub>IH</sub>	2.2	—	VDD	V
Input Low Voltage	V <sub>IL</sub>	0	—	0.6	V
Output High Voltage	V <sub>OH</sub>	2.4	—	VDD	V
Output Low Voltage	V <sub>OL</sub>	0	—	0.4	V

