

HF1602H

SHANGHAI HENGFANG ELECTRONIC CO.,LTD
 Address: 上海市北京东路668号 赛格电子 2A13 B318
 Tel:021-53085818 53081376 51571718
 FAX:021-53085818 Postcode:200010
 E-Mail:wanghx70@163.com Http://www.hengfang.com.cn

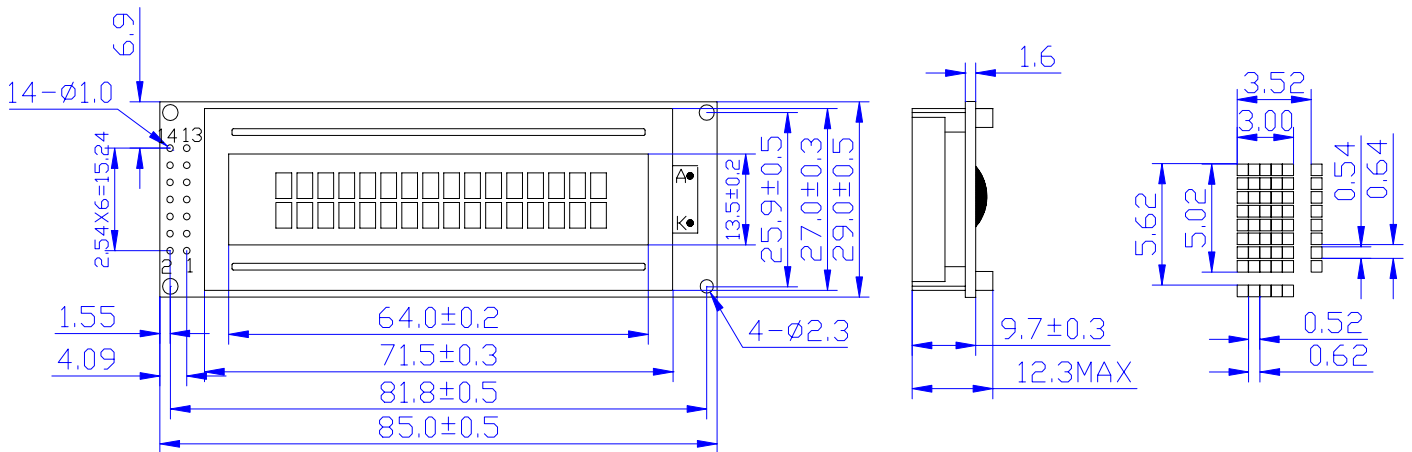

MECHANICAL DATA

Item	Nominal Dimensions	Unit
Module Size(W×H×T)	85.0 × 29.0 × 12.3	mm
Viewing Area(W×H)	64.0 × 13.5	mm
Character Size(W×H)	3.00 × 5.02	mm
Dot Size(W×H)	0.52 × 0.54	mm

PIN CONNECTIONS

PIN	Symbol	Level	Function
1	VDD	—	Supply Voltage for Logic(+5V)
2	VSS	—	GND(0V)
3	V0	—	Power supply for LCD
4	RS	H/L	H: Data ; L: Instruction Code
5	R/W	H/L	H: Read ; L: Write
6	E	H/L	Enable Signal
7	DB0	H/L	Data Bus Line
8	DB1	H/L	
9	DB2	H/L	
10	DB3	H/L	
11	DB4	H/L	
12	DB5	H/L	
13	DB6	H/L	
14	DB7	H/L	

ABSOLUTE MAXIMUM RATINGS

Item	Symbol	Min	Type	Max	Unit
Operating Voltage	VDD	4.5	5.0	5.5	V
Operating Current	IDD	1.3	1.5	2.0	mA
LED Voltage	V _{LED}	4.5	5.0	5.5	V
LED Current	I _{LED}	70	120	180	mA
Operating Temp.	T _{opr}	-20	—	+70	
Storage Temp.	T _{sto}	-30	—	+80	

ELECTRICAL CHARACTERISTICS

Item	Symbol	Min	Type	Max	Unit
Input High Voltage	V _{IH}	2.2	—	VDD	V
Input Low Voltage	V _{IL}	0	—	0.6	V
Output High Voltage	V _{OH}	2.4	—	VDD	V
Output Low Voltage	V _{OL}	0	—	0.4	V

BLOCK DIAGRAM

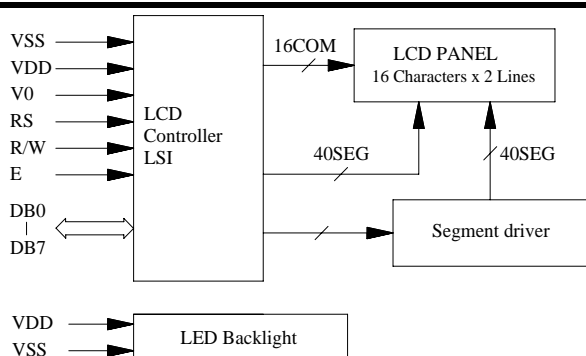

POWER SUPPLY

